

# ET-040-PL-230-RD

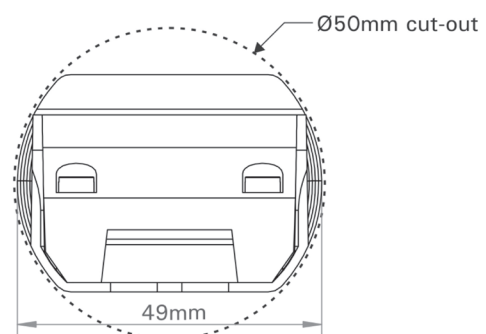

Mode are known throughout the lighting industry for manufacturing a superior range of high frequency Electronic Transformers for use with low voltage and LED lighting. Since 1990, Mode Transformers have been specified by many leading lighting designers and luminaire manufacturers. They require a reliable product which can be dimmed by all types of dimmer and so avoid any compatibility issues. Mode Transformers can be dimmed by leading or trailing edge, commercial (hard fired) or domestic (diac), resistive or inductive dimmer types.

## Product Dimensions

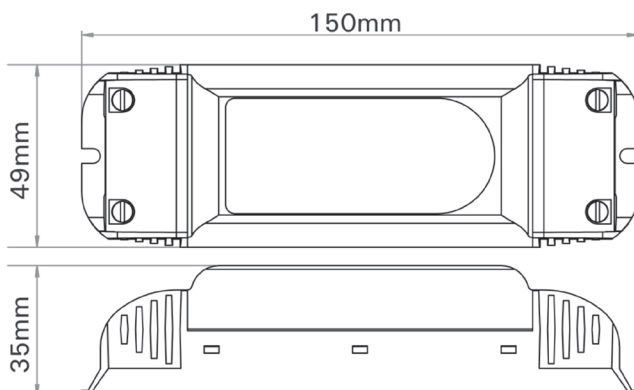

## Key Features

- » High Frequency 12V AC Output.
- » Suitable for LED halogen replacement loads hard from 5W up to 40W.
- » Dimmable with domestic, hard-fired, leading and trailing edge dimmers.
- » Self resetting, short circuit and overload protection.
- » Complies with EC EMC and Low Voltage Directives.
- » Complies with EMC Emission Standard EN 55015.
- » Complies with EMC Immunity Standard EN 61547.
- » Energy efficient, ensures cool operating temperature.
- » Double insulated Class II. SELV equivalent.
- » Flame retardant moulded enclosure, UL94-V0.
- » Lightweight and compact size, only 150 grams.
- » Very low audible noise for demanding applications.
- » Mode products are guaranteed for two years.

## Wiring Diagram

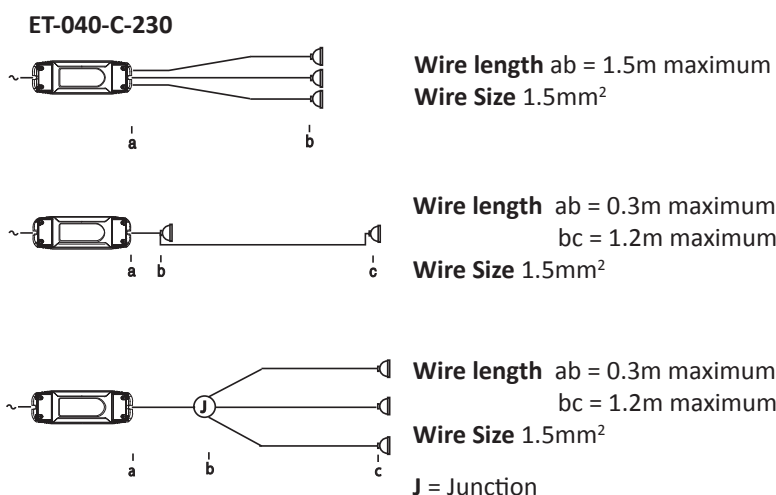

### Note

Installation should be in accordance with the relevant National Wiring Regulations and other applicable Regulations. Compliance to the EC EMC and Low Voltage Directives may be invalidated if not used or installed according to the published specification. Electronic Transformers should be located in well ventilated areas and should not be covered or enclosed by insulating materials.

Electronic Transformers operate at high frequencies. The output voltage cannot be measured on a standard voltmeter. The output leads should not be separated by more than 10mm and should be kept to a minimum length to achieve optimum regulation and EMC suppression. Electronic Transformers are not recommended for parallel rod or tensioned wire lighting systems. Observe dimmer manufacturer's recommended load ratings.

## Technical Data

Information	ET-040-PL-230-RD
Input Voltage	230 +/- 10%
Output Voltage	11.7V RMS nominal
Input Current	0.3 Amp nominal
Output Current	3.5 Amp nominal
Input Power	0.99
Output Power	5-40VA
Input Frequency	50/60Hz
Output Frequency	40KHz
Input Terminals	2 x Live, 2 x Neutral
Output Terminals	3 x 12V, 3 x 0V
Temperature - Case Rise	35°C maximum
Temperature - Ambient	40°C maximum
Temperature - Case	75°C maximum
Protection - Short Circuit	Auto-reset
Protection - Overload	Auto-reset
Protection - Thermal	Auto-regulating
Fusing - Primary	Non replaceable fuse
Fusing - Secondary	None required
Weight	150g
Regulation	Better than 3.5%
Standards	EN 61347-2-2, EN61000-3-2, EN61000-3-3, EN 61547 and EN55015

