

SET-SEN-DIM-RM-P

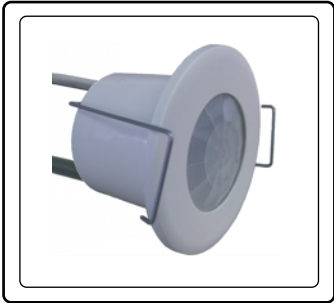

The SET-SEN-DIM-RM-P is a Recessed Mounted Presence sensor for installation in ceiling tiles or plasterboard type ceilings

The SET-SEN-DIM-RM-P is a true multi-sensor, mains powered, self contained, occupancy and light level sensor which has been designed to automatically switch lighting on when movement from body heat has been detected. It will automatically switch it off again once movement has ceased following a preset adjustable time delay.

The SET-SEN-DIM-RM-P is capable of providing a DALI*, DSI or 1-10V analogue output. It provides automatic daylight linking dimming based on natural daylight ingress. (*Broadcast only).

WARNING. This product works at mains potential. Be sure to take care when working with electricity. This product should only be installed by a qualified electrician in accordance with the latest edition of the IET wiring regulations and this instruction leaflet.

Location

Before installing the sensor, care should be taken in where it will be located. Please refer to 'PIR Do's and Don'ts' and the 'Light Level - Do's and Don'ts' below for further information.

PIR - DO'S and DON'TS

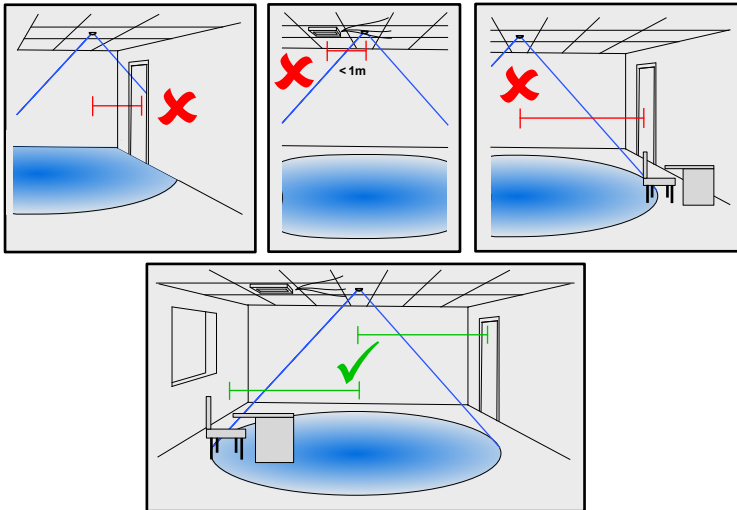

Light Level - DO'S and DON'TS

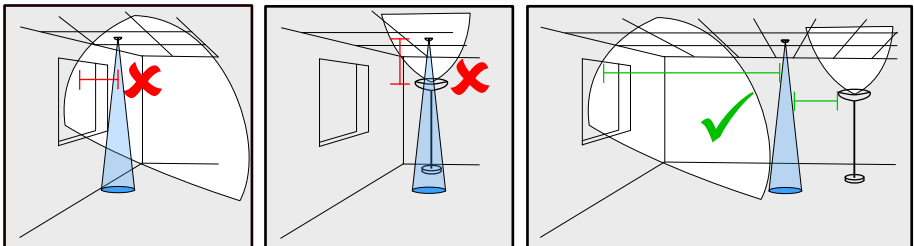

Fitting a SET-SEN-DIM-RM-P

This sensor is required to be installed into a false ceiling or ceiling tile. First cut a hole of 46mm approximately in the ceiling tile. Bend and hold the spring clip together above the plugs before inserting the spring clip and sensor body into the hole. Secure the sensor by slowly releasing the spring clip (see 'Mounting Diagram' below). For single sided fitting, insert only the spring clip and allow it to pull the sensor body into the hole.

MOUNTING DIAGRAM

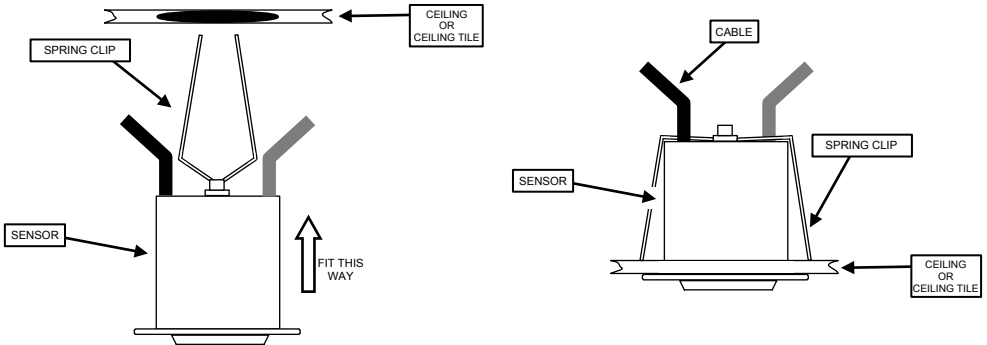

DIMENSIONS

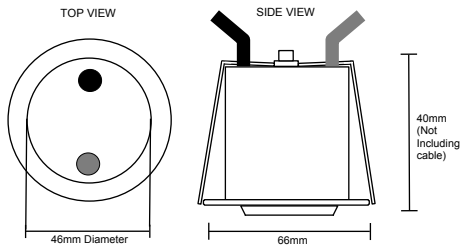

CONNECTION DIAGRAM

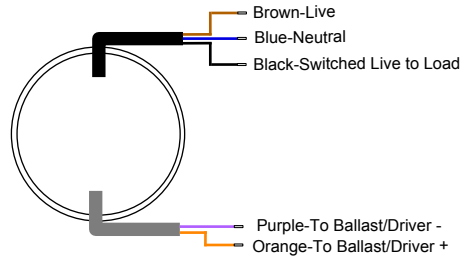

Wiring the sensor

Important: Before commencing to connect the sensor to the supply, please ensure that circuit you are about to work on is isolated. Connect the sensor to a permanent 230V AC supply as per the 'Wiring Diagram' below.

WIRING DIAGRAM

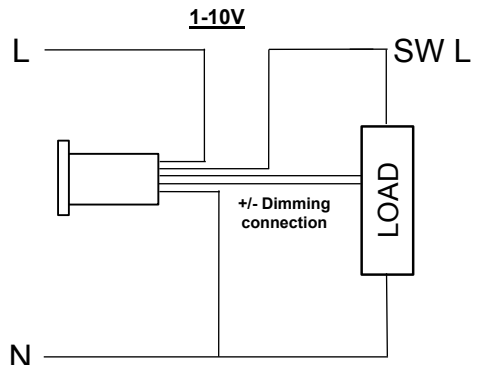
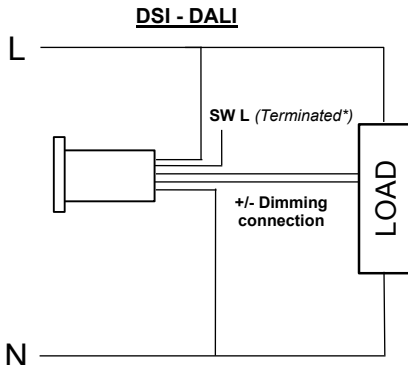

* When used with digital dimming ballasts/drivers a permanent live supply is required. Terminate SW/L connection appropriately.

Detection Pattern

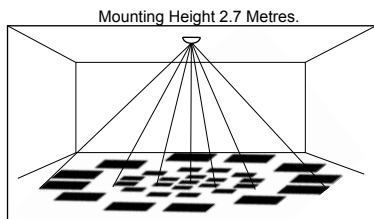

Diameter of detection pattern 7 metres.
Sensitivity of detection gradually decreases towards the perimeter of the detection pattern.

Function of LED

MODE	Normal Operation	Burn IN	IR Command Valid	IR Command Invalid
LED				
STATUS	Amber flashes when movement detected.	Constant Red.	Alternating Red/Amber four times.	Red flashes four times.

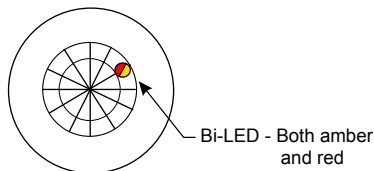

Burn in

Most fluorescent lamp manufacturers will require the lamps to be on at maximum output for a set period of time (*refer to the Manufacturer's data sheet for details*) to help guarantee lamp life. Further information can be found in the SET-SEN-PROG-01 programming guide.

Testing and commissioning requires a SET-SEN-PROG-01 or SET-SEN-PROG-02 remote control. (*Sold separately*)

The SET-SEN-DIM-RM-P is supplied with factory settings (see below).

SET-SEN-DIM-RM-P	Factory settings
Output	DALI*
Daylight Linking	ON
LUX Level	40*
Minimum Dim Level	1%
Maximum Dim Level	100% (<i>full</i>)
PIR	ON
Occupancy Timeout	10:00 Minutes
Occupancy Mode	Presence detection
After Occupancy	Dim to OFF
Relay	OFF
Gain	4 (Medium)

FACTORY SETTINGS EXPLAINED

What is LUX?

This is used as a measure of light intensity, as perceived by the human eye.

*LUX Level = 'Desired LUX level' divide by 10 = LUX Level
example: '400' LUX level divide by 10 = 40. Then enter 40 into SET-SEN-PROG-01 control (*sold separately*). This level is taken at the face of the sensor.

Minimum dim level: The level the light will dim down to.

Maximum dim level: The level the light will dim up to.

What is Daylight Linking Dimming?

This is when the artificial light level in the room is automatically adjusted by the sensor based on the natural ingress of daylight.

What is Gain?

Gain is the sensitivity setting of the PIR, ranging from 1 (*minimum*) to 8 (*maximum*).

*DALI broadcast only.

Technical Data.

Mounting Details: Ceiling mounted, recessed.

Sensor Type: Dual Element (Ying-Yang) 360° Pyroelectric Passive Infra-Red detector, detects body heat.

Coverage: 360° Field Of View. Coverage and sensitivity is dependant on mounting height. (mounting height x 2.5 = diameter of coverage). Typically 7m diameter.

Maximum Mounting Height: 4 metres.

Photodiode: Range = 25 to 2,000 Lux +/- 10%

Supply Voltage: 100-240V A.C. 50Hz. (85-265 Min-Max)

Switching Capacity: 9 high frequency ballasts or drivers. 3 Amp inductive. Inrush current 80 Amp for no longer than 20ms.

Dimming Output: DSI, DALI* or 1-10V(*Broadcast only). This is not an SELV output and should be treated as if at mains potential.

Dimming Capacity: Up to 9 DALI, DSI or 1-10V ballasts/drivers.

Time Delay: Adjustable between 1 to 100 minutes. Test mode = 10 seconds.

Cable: Length - 1.5m: 1 x Black sheath 3 Core (1mm² CSA) and 1 x Grey sheath 2 core (0.5mm² CSA) LSOH.

Dimensions: L = 40mm x Dia = 46mm. Minimum void = 70mm.

Material: Flame retardant ABS/PC UL 94-V0. RAL 9010.

Weight: 280 grams.

I.P. Rating: IP50.

Operating Temperature: -20°C to + 60°C.

Accessory Options.

PART CODE

SET-SEN-PROG-01
SET-SEN-PROG-02

DESCRIPTION

Infrared programmer - Handheld with LCD screen.
Infrared programmer- Basic version- 2 button.

WARNING

This product contains electronic devices.

Do not perform any high voltage tests on this product or to any equipment connected to it. Mains connections can be high voltage tested in accordance with BS 7671:2008, IET Wiring Regulations 17th Edition section 612.3.3.

The SET-SEN-DIM-RM-P is part of a range of energy conservation products available from Setsquare.
This apparatus may be turned on by high powered RF interference and should not be installed near pager aerials or Inductive loop equipment. It will recover when the RF ceases.



WEEE Directive.

Electrical and electronic equipment should never be disposed of with general domestic or commercial waste but collected for their proper treatment and recovery. The crossed out wheellie bin symbol is to remind you of the need to dispose of this product at the end of its life in a way that will assist in the recovery, recycling and reuse of many of the materials used in this product. Where possible also recycle the packaging.



Setsquare Energy Saving Controls
The Maltings
63 High Street
Ware
Hertfordshire
SG12 9AD
United Kingdom



☎ 01920 462121

📠 01920 466881

✉ sales@modelighting.com

🌐 www.setsquare.com

SET-SEN-DIM-RM-P Installation Instructions 19/04/2016
DS464 V1.0