

Intelligent Power Unit: Eight Channel



The Mirage SPP-06-08 is a wall mounting, eight channel, Intelligent Power Unit designed for the reliable mains dimming of resistive or inductive lighting loads or switching/1-10V HF fluorescent loads (maximum 4 channels).

Each of the eight circuits is rated at 6.6A resistive or inductive and is protected by an 8A Type C Miniature Circuit Breaker (MCB). This unit contains a programmable processor to provide scene setting lighting control.

Additional control inputs may be in the form of DMX512 or RS-232 protocols. Control plates and further power units are connected and communicated via the Mode Tiger Bus. Partitioning, Infrared and an automated time clock facility are also available.

Key Features

- » Eight dimmable channels of 6.6A resistive or inductive loads.
- » Selectable switched/1-10V control (for channels 5-8 only).
- » Up to 1.5A of compatible LED load per channel.
- » Leading Edge Dimming Technology.
- » Control input Tiger/Scenario Bus, DMX512 and RS-232.
- » Individual 8A Type C MCB Circuit Protection.
- » Emergency Fixed Live MCB protected outputs for maintained emergency supplies.
- » Built in Scene Setting processor.
- » LED channel monitor to indicate the operation of each output.
- » Programmable scene levels and fade rates.
- » Supply input 230/240V. 50-60Hz. 2 x 24A maximum (100-125V option available).
- » Internal test switch (2) to enable all eight channels to be locally tested to full on.
- » Triacs with screw fixings can be removed for servicing.
- » Conduit cable entries (eight) 25mm diameter suitable for use with conduits and trunking.
- » Complies with EC EMC and Low Voltage Directives (CE).
- » 2 year warranty.



System Architecture

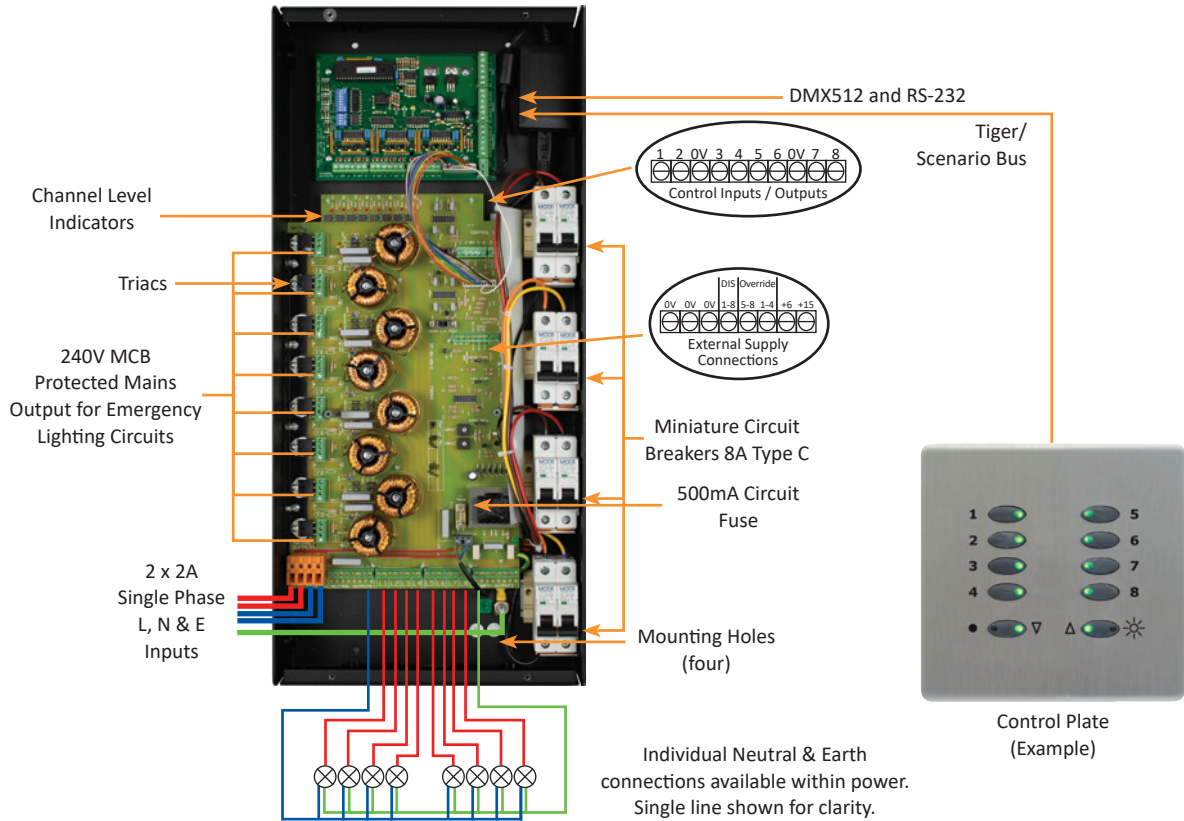

Technical Data

Power	
Mains Supply	» 230V AC +/- 10% 50/60Hz, single phase, 2 x 24A maximum (Same phase)
Control Fuse	» 20mm x 5mm 500mA HRC ceramic
Earth	» This product must be earthed
Connections & Cable Specifications	
Channel Outputs	» Eight channels of 6.6A resistive or inductive loads » 1-10V HF LED drivers (max 4 channels) » Up to 1.5A for LED loads depending on LED de-rating factor » Check with LED lamp manufacturer for recommended number of lamps on an 8A MCB or RCBO*
Load MCB	» Individual Miniature Circuit Breaker (MCB) 8A Type C
Control Input	» Tiger/Scenario Bus, DMX512 or RS-232
Override	» Low voltage override using latching device
Mechanical	
Standards	» EN55015, EN61547, EN61000-3-2, EN61000-3-3, EN60439-1, EN60950
Conduit Entries	» Eight off 25mm diameter
Dimensions	» 470mm High x 262mm Wide x 75mm Deep
Fixing Centres	» 432mm x 138mm
Weight	» 4.7kgs
Packed Size	» 485mm High x 280mm Wide x 90mm Deep
Packed Weight	» 5kgs

Note

For additional technical information refer to Installation Guide SPP-06-08.

*The maximum number of lamps on a circuit and dimming performance will vary for different lamps and manufacturers. Users should verify performance and dimming range with the lamp manufacturer. For further advice please contact your local distributor or the Mode Lighting Technical team.

Installation should be in accordance with the relevant National Wiring Regulations and other applicable Regulations. Compliance to EC EMC and Low Voltage Directives may be invalidated if not used or installed according to the published specification.

SPP-06-08 should be located in well ventilated areas and should not be covered or enclosed by insulating materials.

Mode reserve the right to amend the product specification or design at any time and without notice.



Mode Lighting Limited. The Maltings, 63 High Street, Ware, Hertfordshire, SG12 9AD. United Kingdom.
Tel: +44 (0) 1920 462121 | Fax: +44 (0) 1920 466881 | Email: sales@modelight.com | www.modelight.com