

Slave Power Unit 12 x 3A - TE

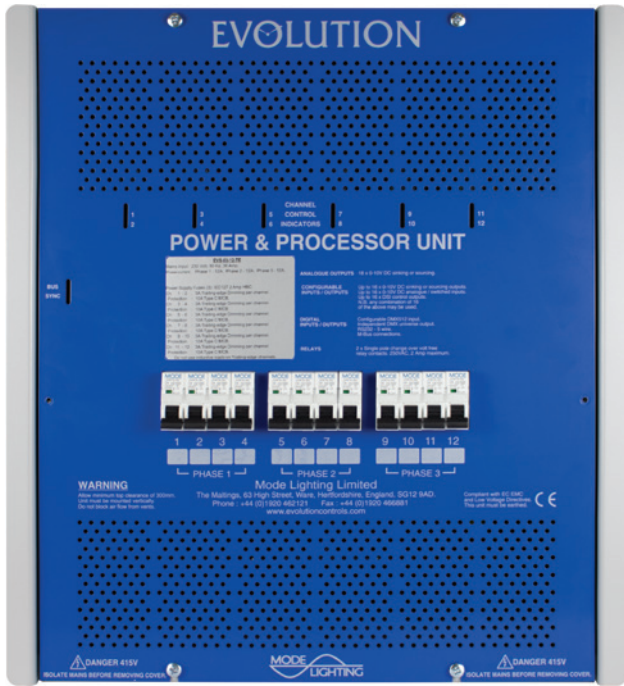

The EVS Slave Power Units are designed specifically for the control of Trailing Edge controllable loads i.e. certain electronic LV transformers, filament lamps and the latest generations of dimmable low energy lamps and LED drivers.

EVS Slave Power Units build on the quality and reliability of Mode product designs and offers high specification control and power management in a mechanically, electrically and thermo dynamically designed unit.

Key Features

- » Twelve dimmable channels of 3A trailing edge loads.
- » Trailing Edge Dimming Technology.
- » Slave Unit for use with Evolution and eDIN+ Systems.
- » Individual 10A Type C MCB Circuit Protection.
- » Emergency Fixed Live MCB protected outputs (2 per phase) for maintained emergency supplies.
- » Test mode for quick installation and testing.
- » DIN rail mounted wiring terminals.
- » Supply input 230/240V. 50-60Hz. Single or three phase options.
- » Complies with EC EMC and Low Voltage Directives (CE).
- » 2 year warranty.



System Architecture

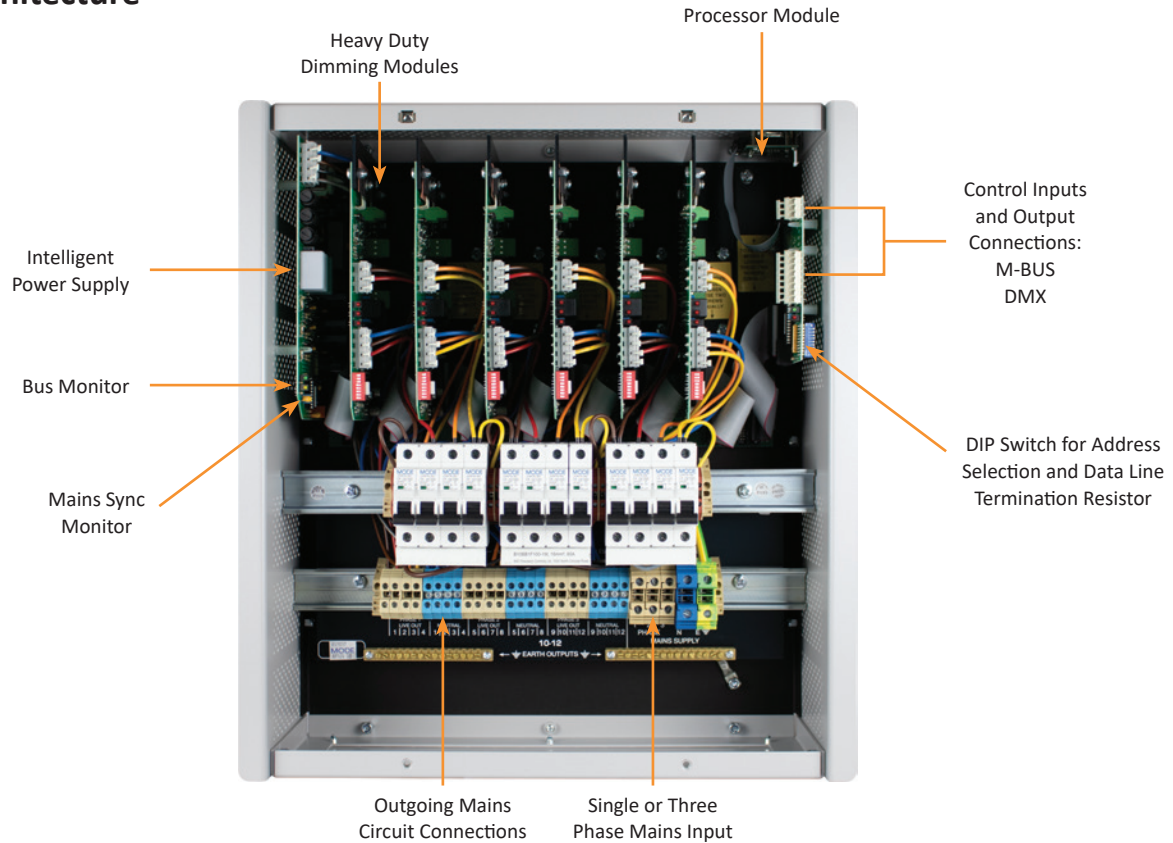

Technical Data

Power	
Mains Supply	» 230V AC +/- 10% 50/60Hz, single or three phase options
Control Fuse	» 20mm x 5mm 2A HRC ceramic (3)
Connections & Cable Specifications	
Channel Outputs	» Twelve channels of 3A Trailing Edge loads only » Check with LED lamp manufacturer for recommended number of lamps*
Circuit Protection	» Individual Miniature Circuit Breaker (MCB) 10A Type C » RCBOs available to special order
Control Input	» M-BUS, DMX
Mechanical	
Standards	» EN55015, EN61547, EN61000-3-3, EN60439-1, EN60950
Conduit Entries	» Eight off 32mm diameter or removable panel
Dimensions	» 534mm High x 482mm Wide x 160mm Deep
Fixing Centres	» 452mm x 464mm
Weight	» 17kgs
Packed Size	» 600mm High x 550mm Wide x 250mm Deep
Packed Weight	» 18kgs

Note

For additional technical information refer to Installation Guide EVS-03-12-TE.

*The maximum number of lamps on a circuit and dimming performance will vary for different lamps and manufacturers. Users should verify performance and dimming range with the lamp manufacturer. For further advice please contact your local distributor or the Mode Lighting Technical team.

Installation should be in accordance with the relevant National Wiring Regulations and other applicable Regulations. Compliance to EC EMC and Low Voltage Directives may be invalidated if not used or installed according to the published specification.

EVS-03-12-TE should be located in well ventilated areas and should not be covered or enclosed by insulating materials.

Mode reserve the right to amend the product specification or design at any time and without notice.



Mode Lighting Limited. The Maltings, 63 High Street, Ware, Hertfordshire, SG12 9AD. United Kingdom.
Tel: +44 (0) 1920 462121 | Fax: +44 (0) 1920 466881 | Email: sales@modelight.com | www.modelight.com