



**MODE**  
**LIGHTING**  
CONTROL PLATES

*where STYLISH DESIGN meets SMART CONTROL*





## index

Design Ethos	3
COOLBRIUM	5
iCON	9
GENEVA	13
EVO-ELLIPSE	17
Custom Built Plates	21
Bespoke Control	23
Digital Rotary	25
Standard Switches	27
Touch Screen	29
App Control	33
Colour Palette	37
Plate Compatibility	39
About Us	41

# DESIGN ETHOS

building on over 45 years  
of UK design and manufacture

3

Personal, tailored lighting control.

Simple and intuitive functions.

Crafted in the UK.

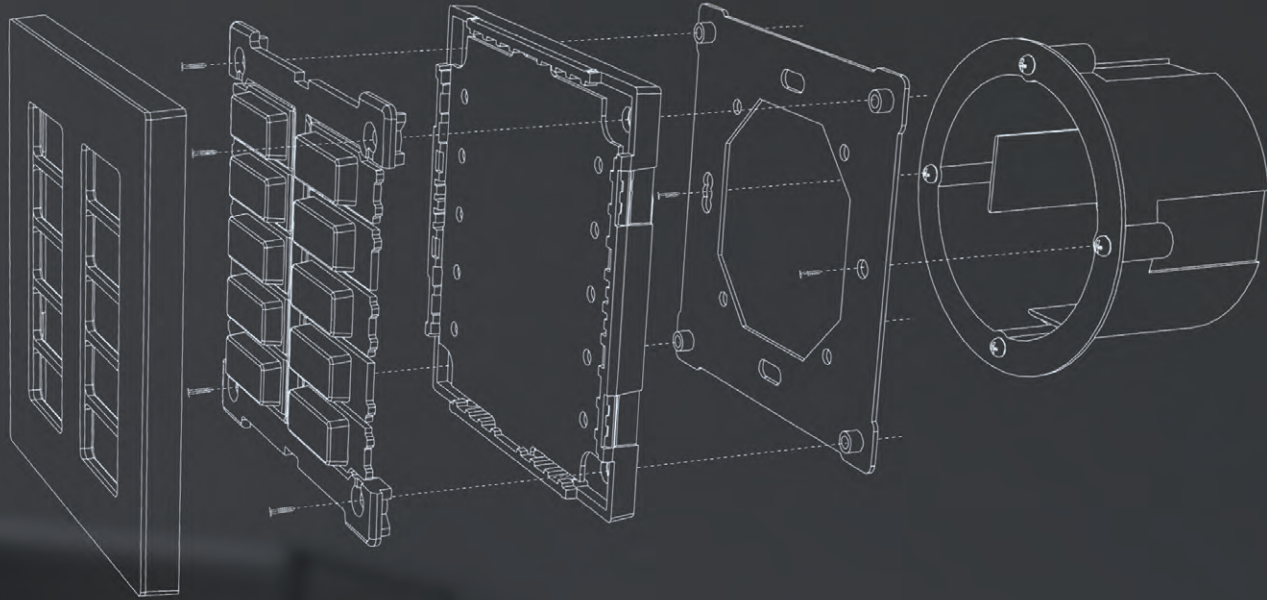

# COOLBRIUM

inspired by touch controls and smart technology

5

A keypad with smart phone inspired buttons.

Touch sensitive control with engravable glass.

Standard and custom engraving.

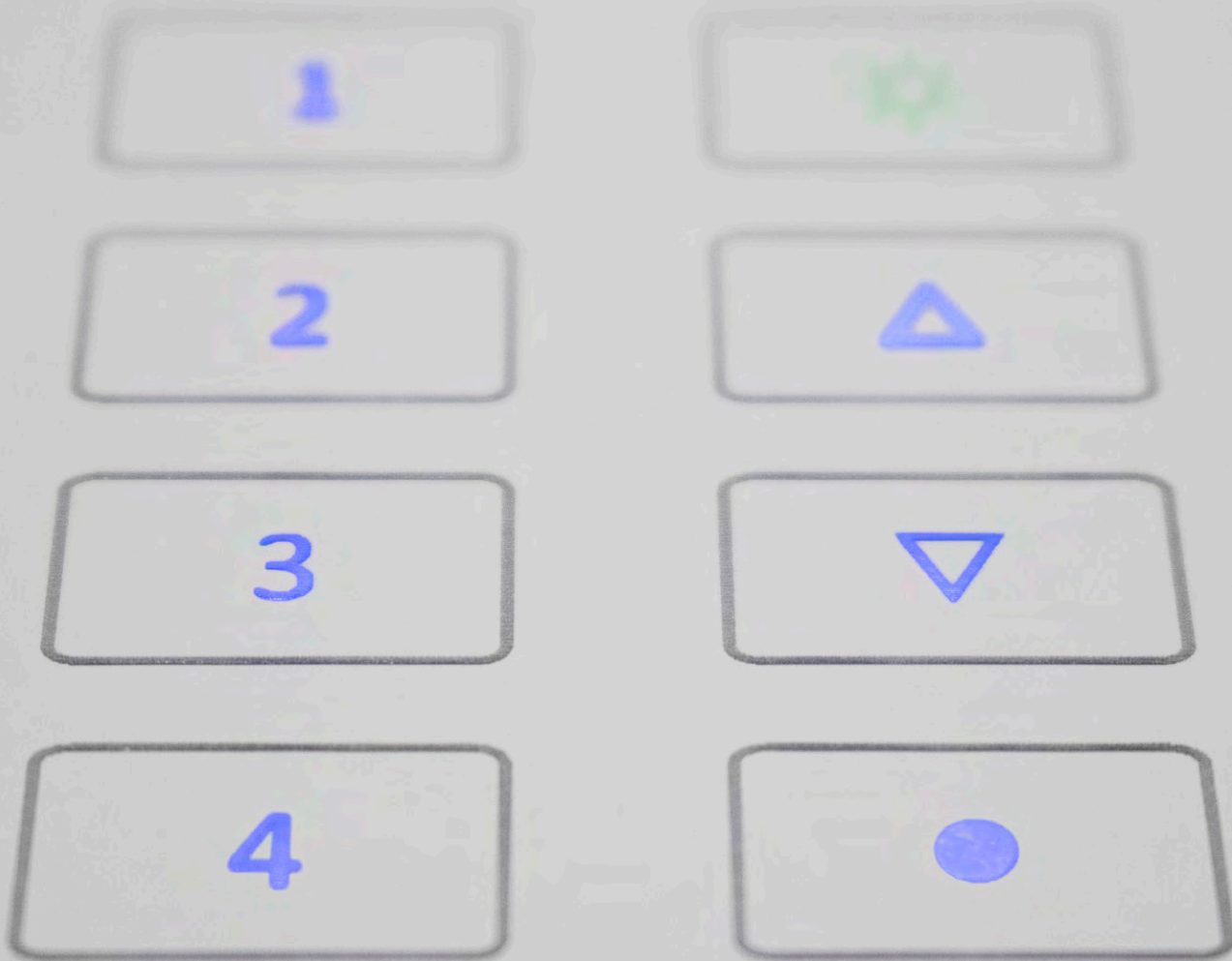





# COOLBRIUM



ONYX BLACK GLASS  
(BLK)



ICE WHITE GLASS  
(WHI)

- Eight programmable buttons
- Onyx Black and Ice White Glass finishes available

# *i*CON

influenced by symbolism and architectural design

A keypad with a sleek, screwless design.

9

Architect inspired styling with engravable buttons.

MK Aspect screwless plates.

Rectangular button style.

Standard and custom engraving.







WHITE  
(WHI)



BRUSHED STAINLESS  
STEEL (BSS)



POLISHED CHROME  
(POC)



ANTIQUe BRONZE  
(ABZ)

- Up to ten programmable buttons
- A range of different finishes available.

# GENEVA

design led by modern and sleek dynamic symmetry

Custom integration tailored for European and UK projects.

13

A modern keypad with an elegant design.

Bespoke plate design.

Rectangular button style.

Standard and custom engraving.

HOLIDAY

WELCOME

CINEMA

PARTY

ON/OFF



15





# GENEVA



WHITE  
(WHI)



BRUSHED STAINLESS  
STEEL (BSS)



ANTHRACITE  
(ANT)

- Up to ten programmable buttons
- A range of different finishes available

# EVO-ELLIPSE

a screwless, slim and stylishly elegant soft touch design

Soft touch buttons for simple operation.

Discrete oval button styling for minimalist applications.

MK Aspect screwless plates.

Standard and custom plate engraving.





19



# EVO-ELLIPSE



WHITE  
(WHI)



BRUSHED STAINLESS  
STEEL (BSS)



POLISHED CHROME  
(POC)



POLISHED BRASS  
(PBR)

- Up to ten programmable buttons
- A range of different finishes available

# CUSTOM BUILT PLATES

The ICON and EVO-ELLIPSE ranges are built onto MK Aspect plates as standard.

21

Alternative accessory manufacturers may also be used.

Companies that have partnered with Mode includes:

- Forbes and Lomax
- Heritage Brass
- Wandsworth
- Focus SB
- Hoad & More
- Hamilton



# BESPOKE CONTROL

custom plate / button engraving for configurable control

Any button can perform any task... decide on the function or scene you wish to create, then choose a symbol, word or even design your own symbol.

23

Client selectable plate and button engraving to suit any requirement.

Configurable control:- Local and global scene selection

- Toggle on/off control
- Impulse on/off/dim control
- On/up, off/down, up/down
- Selectable button LED colours
- BMS and AV command triggers





# DIGITAL ROTARY

traditional control... for the modern world

Conventional rotary “dimmer” for dim up/down control.

Single or multi-channel operation.

Integrates with scene setting control.

Multi-position flexibility.

Standard and Custom Plates available.



# STANDARD SWITCHES

27 Mode Lighting also offer a range of interfaces to work with standard electrical switches. Available in modern, classic and antique finishes to suit any style of project.

Working closely with some of the highest quality plate manufacturers, our systems integrate with any style of control your project requires.



Rocker



Bell Push / Toggle

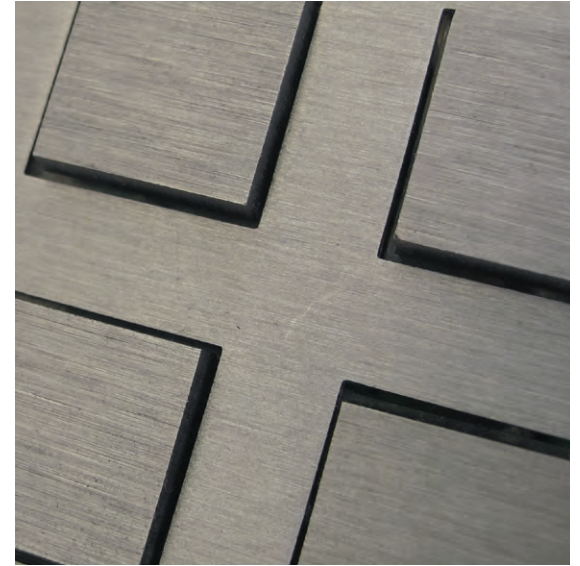

Push Button

- Integration with standard electrical switches
- Flexible control
- Custom interfacing

# TOUCH SCREEN

elegant total system control at a touch

Easy to use Touch Screen.

7" colour display

Optional black or white finishes.

Supplied with flush mount back box.

Pre-installed eDIN+ App Control software.



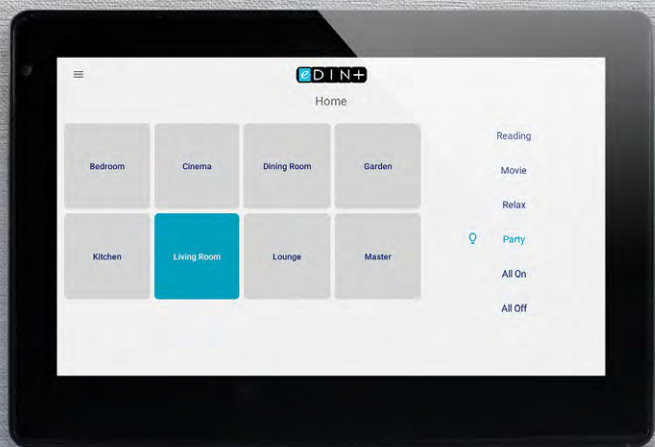

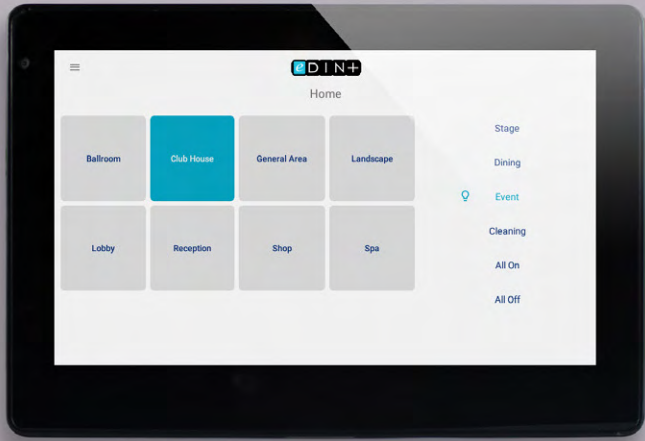



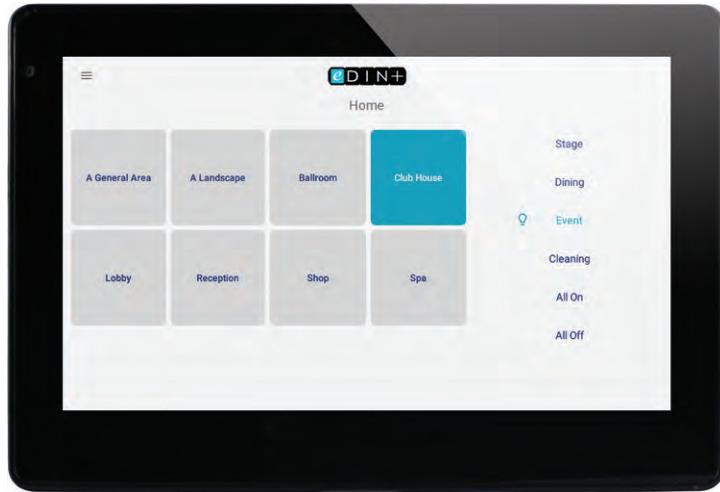

BLACK TOUCH SCREEN  
(BLK)

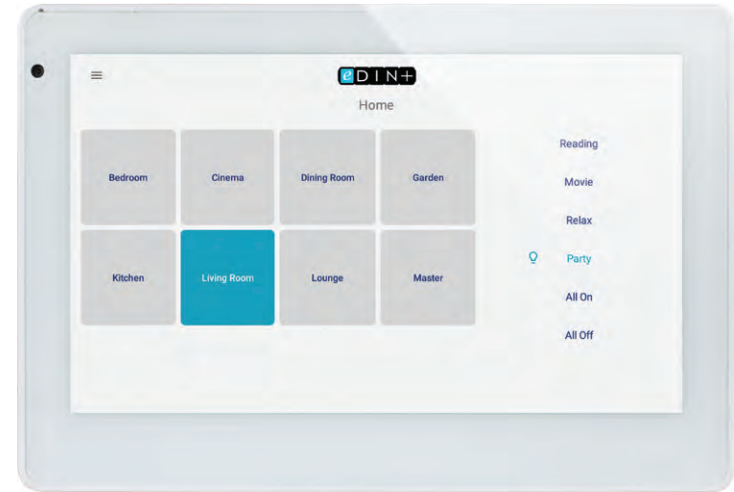

WHITE TOUCH SCREEN  
(WHI)

- Easily select local and global scenes
- Save popular scenes to favourites for faster control of your lighting

# APP CONTROL

simple and stylish total system control

33 Networked systems can be controlled by a simple App, allowing room by room or global scene selection and adjustment, putting your project in your control.

The App lets you conveniently control your smart home or commercial project with ease. Whatever command you want to perform the Mode Lighting App makes it simple and quick.



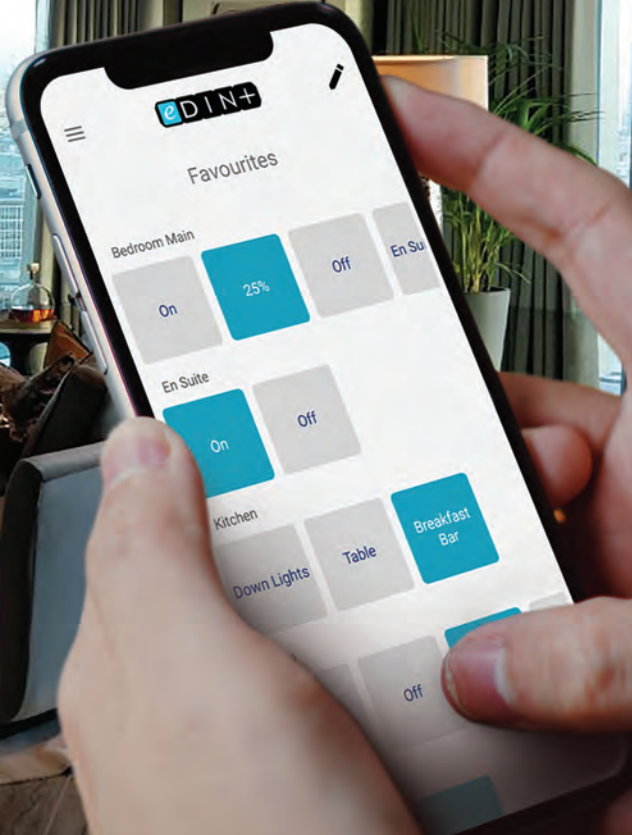



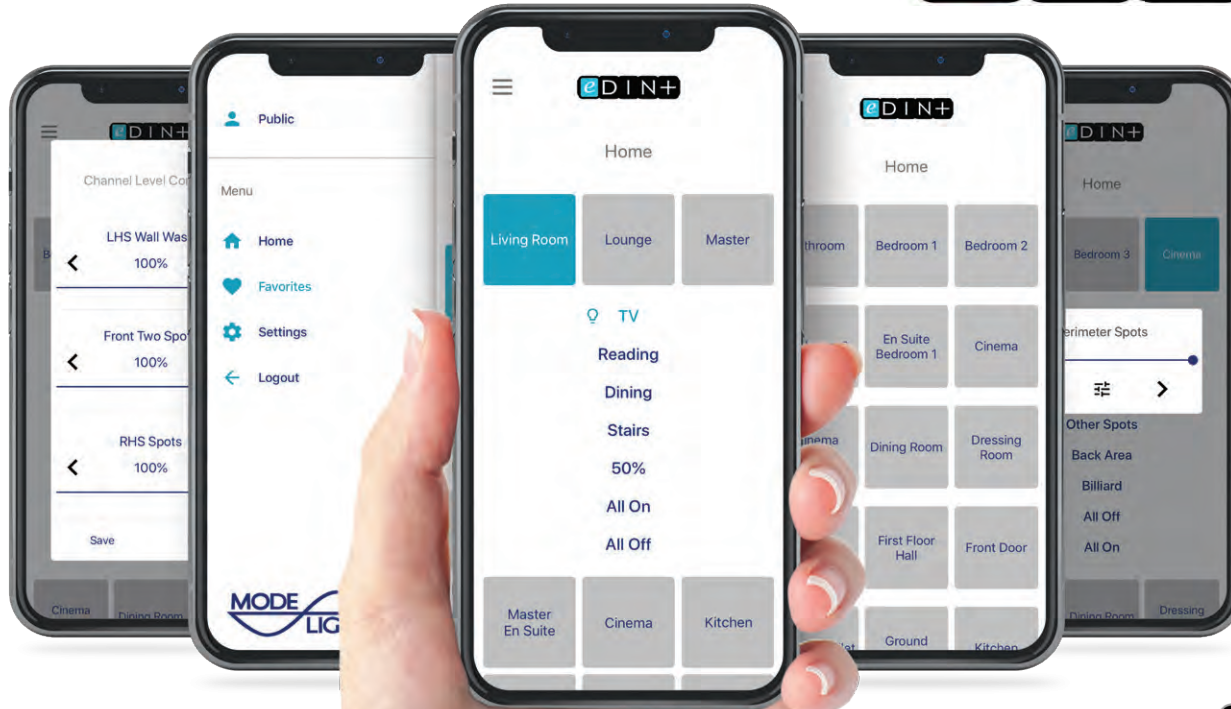

- Convenient complete control
- Quick setup
- Intelligent intuitive features
- Available on Apple® and Android™ devices



# COLOUR PALETTE

custom plate finishes are available on request

## Standard Plate Finishes - MK Aspect

37



**BSS**  
Brushed Stainless Steel



**WHI**  
White



**PBR**  
Polished Brass



**POC**  
Polished Chrome



**ABZ**  
Antique Bronze

## Custom Plate Finishes - MK Aspect



**BNK**  
Brushed Nickel



**NKL**  
Polished Nickel



**CHA**  
Charcoal



**BLK**  
Black



**AB**  
Antique Brass



# PLATE COMPATIBILITY

		COOLBRIUM	iCON	GENEVA	EVO-ELLIPSE
39 Plate Finishes	MK Aspect Colour Palette		●		●
	Glass (Black & White)	●			
	Square Cut Finishes			●	
	Custom Finishes		●		●
Plate Design	Button Engraving	●	●	●	
	Plate Engraving		●		●
	Button Layout	8/4 Buttons	10/7/5/2 Buttons	10/5 Buttons	10/5/2 Buttons
Back Box Fit	UK Fit	●	●	●	●
	European Fit			●	



# CREATE-A-PLATE

— Control Plate Part Code  
 — Fascia Part Code

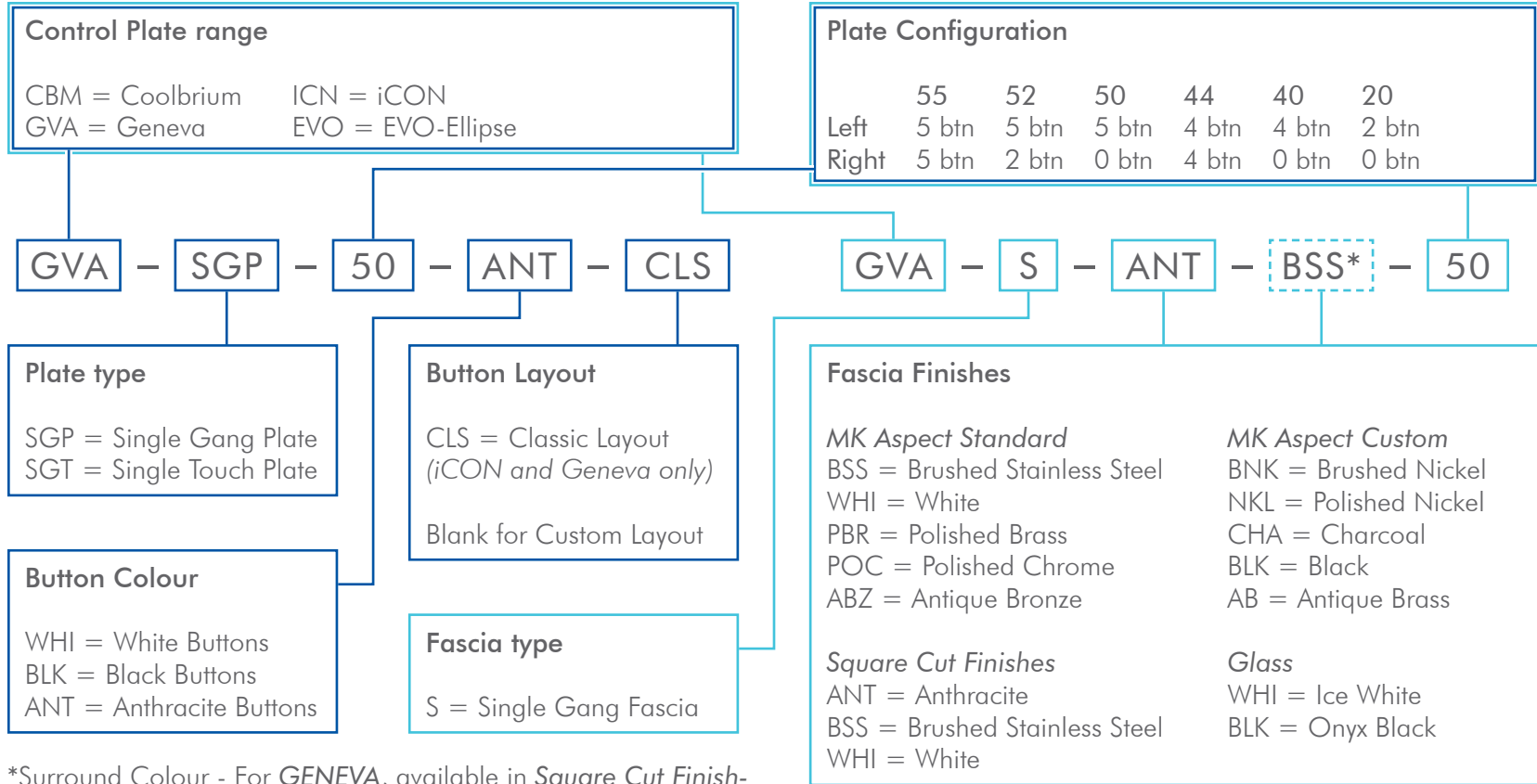

# ABOUT US

dedicated to providing intelligent control with beautiful design

Established 1970.

Privately Owned Company.

In-House Design and Manufacture.

Based in Hertfordshire, UK.





*“All things in nature are dark, except where exposed by the light.”*

**- Leonardo da Vinci**