

eDIN+ Power Pack

09 Channel

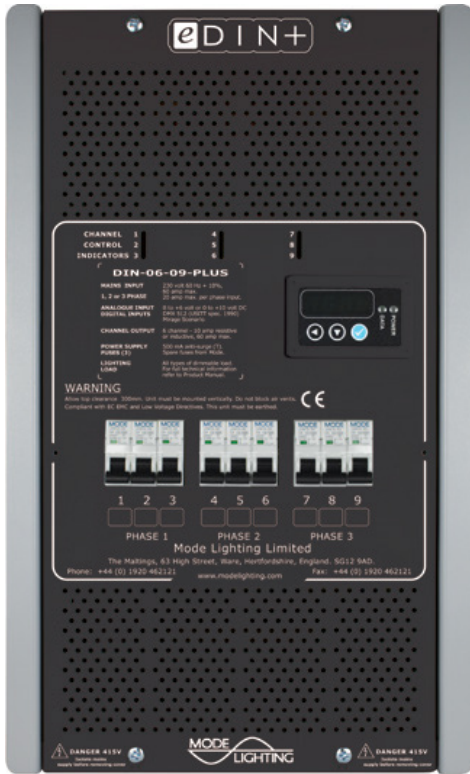

The eDIN+ Power Pack brings together the rugged, high power Mains Dimming and Switching performance of traditional Mode Dimmers with the flexibility of the eDIN+ Control System offering simple programming and operation with scalable control and intelligent logic functions.

Available in a number of standard formats the eDIN+ Power Packs can also be configured to have a mixture of Leading Edge, Trailing Edge and Relay Switching Power Cards allowing units to be tailored to individual projects.

Supplied with individual circuit protection as standard the eDIN+ Power Packs are available with either MCB or RCBO protection.

Key Features

- ▶ Nine channels of either Leading Edge Dimming, Switching or Trailing Edge Dimming
- ▶ Up to 1.5A of compatible LED load per channel.
- ▶ Intelligent self monitoring power supply.
- ▶ Individual 'Type C' MCB or RCBO Circuit Protection.
- ▶ Emergency Fixed Live protected outputs (2 per phase) for maintained emergency supplies.
- ▶ DIN rail mounted wiring terminals.
- ▶ Supply input 230/240V. 50-60Hz. Single or three phase options.
- ▶ Complies with EC EMC and Low Voltage Directives (CE).
- ▶ 2 year warranty



System Architecture

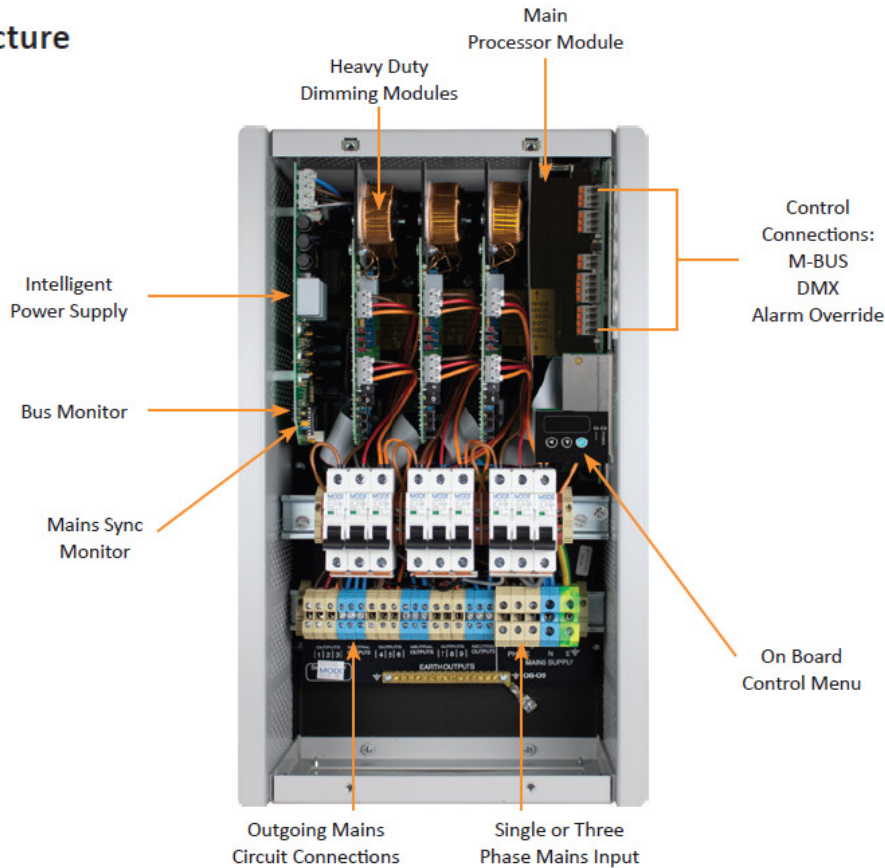

Technical Data	DIN-06-09-PLUS	DIN-06-09-PLUS-RCBO	DIN-03-09-PLUS-TE	DIN-03-09-PLUS-TERCBO	DIN-RP-10-09-PLUS-RCBO
Number of Channels	9 Channels				
Dimming / Switching	Leading Edge / Switching		Trailing Edge Only		Switch Only
Output Load (maximum)	6.6A resistive or inductive loads		3A resistive loads		10A resistive or inductive loads
	1.5A of Compatible LED Load				
Individual Circuit Protection	8A MCB Type C	8A RCBO Type C	8A MCB Type C	8A RCBO Type C	10A RCBO Type C
Control Input	M-BUS via eDIN+ NPU and/or Individual Channel Control via DMX				
Power					
Mains Supply	230V AC +/- 10% 50/60Hz, single or three phase options				
Control Fuse	20mm x 5mm 2A HRC ceramic (3)				
Mechanical					
Standards	EN55015, EN61547, EN61000-3-3, EN60439-1, EN60950				
Conduit Entries	Five off 32mm diameter or removable panel				
Dimensions	534mm High x 322mm Wide x 160mm Deep				
Fixing Centres	452mm x 302mm				
Weight	11kgs				
Packed Size	600mm High x 400mm Wide x 240mm Deep				
Packed Weight	12kgs				

The maximum number of lamps on a circuit and dimming performance will vary for different lamps and manufacturers. Users should verify performance and dimming range with the lamp manufacturer.

For further advice please contact your local distributor or the Mode Lighting Technical team.

Installation should be in accordance with the relevant National Wiring Regulations and other applicable Regulations. Compliance to EC EMC and Low Voltage Directives may be invalidated if not used or installed according to the published specification.

Mode Lighting Limited reserve the right without notice to amend the technical information and specifications.



Mode Lighting Limited. The Maltings, 63 High Street, Ware, Hertfordshire, SG12 9AD. United Kingdom
 Tel: +44 (0) 1920 462121 | Fax: +44 (0) 1920 466881 | email: sales@modelighting.com | www.modelighting.com